

Polished Bends, Tee's & Reducers

All Dixon polished fittings have a surface finish equitant to 150 grit or better OD, and 180 grit or better ID. A maximum of Ra 32 microinch (0.8 micron) is indicated.

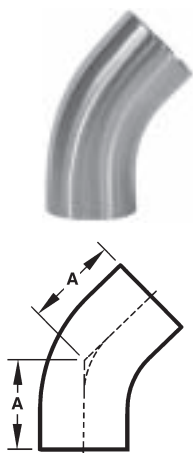

45° POLISHED ELBOWS - BUTT WELD B2KS

PART NO.	TUBE O.D.	DIMENSION A	NOMINAL WALL
B2KS-R50P	½"	2.250	0.065
B2KS-R75P	¾"	2.250	0.065
B2KS-R100P	1"	1.188	0.065
B2KS-R150P	1½"	1.625	0.065
B2KS-R200P	2"	2.312	0.065
B2KS-R250P	2½"	3.000	0.065
B2KS-R300P	3"	3.688	0.065
B2KS-R400P	4"	4.812	0.083

Polished 316L Stainless Steel.

G

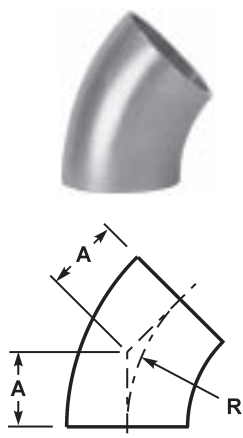

POLISHED ELBOWS LESS TANGENT - B2WK

PART NO.	TUBE O.D.	DIMENSION		NOMINAL WALL
		A	R	
B2WK-R50P	½"	.466	1.125	0.065
B2WK-R75P	¾"	.466	1.125	0.065
B2WK-R100P	1"	.625	1.500	0.065
B2WK-R150P	1½"	.937	2.250	0.065
B2WK-R200P	2"	1.250	3.000	0.065
B2WK-R250P	2½"	1.562	3.750	0.065
B2WK-R300P	3"	1.875	4.500	0.065
B2WK-R400P	4"	2.500	6.000	0.083
B2WK-R600P	6"	3.750	9.000	0.109
B2WK-R800P	8"	5.000	12.000	0.120
B2WK-R1000P	10"	6.250	15.000	0.109
B2WK-R1200P	12"	7.500	18.000	0.120

Polished 316L Stainless Steel.

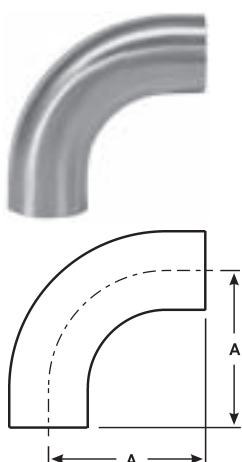

90° POLISHED ELBOWS - BUTT WELD ELBOWS WITH TANGENT - B2S

PART NO.	TUBE O.D.	DIMENSION A	NOMINAL WALL
B2S-R50P	½"	3.000	0.065
B2S-R75P	¾"	3.000	0.065
B2S-R100P	1"	2.062	0.065
B2S-R150P	1½"	2.937	0.065
B2S-R200P	2"	4.062	0.065
B2S-R250P	2½"	5.187	0.065
B2S-R300P	3"	6.312	0.065
B2S-R400P	4"	8.312	0.083

Polished 316L Stainless Steel.

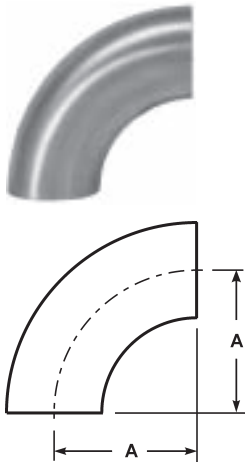

90° POLISHED ELBOWS – BUTT WELD ELBOWS LESS TANGENT – B2WCL

PART NO.	TUBE O.D.	DIMENSION A	NOMINAL WALL
B2WCL-R50P	½"	1.125	0.065
B2WCL-R75P	¾"	1.125	0.065
B2WCL-R100P	1"	1.500	0.065
B2WCL-R150P	1½"	2.250	0.065
B2WCL-R200P	2"	3.000	0.065
B2WCL-R250P	2½"	3.750	0.065
B2WCL-R300P	3"	4.500	0.065
B2WCL-R400P	4"	6.000	0.083
B2WCL-R600P	6"	9.000	0.109
B2WCL-R800P	8"	12.000	0.120
B2WCL-R1000P	10"	15.000	0.109

Polished 316L Stainless Steel.

G

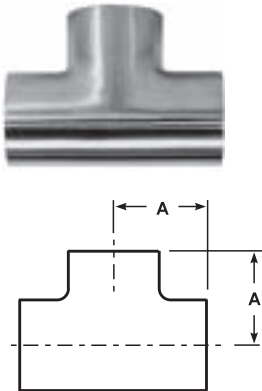

POLISHED TEES – BUTT WELD / SHORT TEE-B7WWW

PART NO.	TUBE O.D.	DIMENSION A	NOMINAL WALL
B7WWW-R100P	1"	1.125	0.065
B7WWW-R150P	1½"	1.656	0.065
B7WWW-R200P	2"	2.062	0.065
B7WWW-R250P	2½"	2.344	0.065
B7WWW-R300P	3"	2.594	0.065
B7WWW-R400P	4"	3.438	0.083

Polished 316L Stainless Steel.

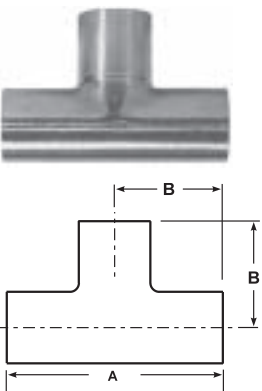

POLISHED TEES – BUTT WELD / LONG TEE – B7W

PART NO.	TUBE O.D.	DIMENSION		NOMINAL WALL
		A	B	
B7W-R50P	½"	3.750	1.875	0.065
B7W-R75P	¾"	4.000	2.000	0.065
B7W-R100P	1"	3.750	1.875	0.065
B7W-R150P	1½"	4.500	2.250	0.065
B7W-R200P	2"	6.000	3.000	0.065
B7W-R250P	2½"	6.000	3.000	0.065
B7W-R300P	3"	6.500	3.250	0.065
B7W-R400P	4"	7.750	3.875	0.083
B7W-R800P	8"	14.000	7.000	0.120

Polished 316L Stainless Steel.

POLISHED TEES – BUTT WELD / REDUCING TEE – B7RWWW

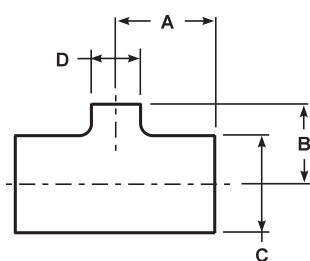

PART NO.	TUBE O.D.	DIMENSION				NOMINAL WALL
		A	B	C	D	
B7RWWW-R7550P	¾" x ½"	2.000	2.000	2.000	2.000	0.065
B7RWWW-R10050P	1" x ½"	2.125	2.125	2.125	2.125	0.065
B7RWWW-R10075P	1" x ¾"	2.125	2.125	2.125	2.125	0.065
B7RWWW-R15050P	1½" x ½"	2.375	2.375	2.375	2.375	0.065
B7RWWW-R15075P	1½" x ¾"	2.375	2.375	2.375	2.375	0.065
B7RWWW-R150100P	1½" x 1"	1.656	1.656	1.656	1.656	0.065
B7RWWW-R20050P	2" x ½"	2.875	2.875	2.875	2.875	0.065
B7RWWW-R20075P	2" x ¾"	2.875	2.875	2.875	2.875	0.065
B7RWWW-R200100P	2" x 1"	2.062	2.062	2.062	2.062	0.065
B7RWWW-R200150P	2" x 1½"	2.062	2.062	2.062	2.062	0.065
B7RWWW-R250150P	2½" x 1½"	2.344	2.344	2.344	2.344	0.065
B7RWWW-R250200P	2½" x 2"	2.344	2.344	2.344	2.344	0.065
B7RWWW-R300150P	3" x 1½"	2.594	2.594	2.594	2.594	0.065
B7RWWW-R300200P	3" x 2"	2.594	2.594	2.594	2.594	0.065
B7RWWW-R300250P	3" x 2½"	2.594	2.594	2.594	2.594	0.083
B7RWWW-R400150P	4" x 1½"	3.438	3.438	3.438	3.438	0.083
B7RWWW-R400200P	4" x 2"	3.438	3.438	3.438	3.438	0.083
B7RWWW-R400250P	4" x 2½"	3.438	3.438	3.438	3.438	0.083
B7RWWW-R400300P	4" x 3"	3.438	3.438	3.438	3.438	0.083
B7RWWW-R600200P	6" x 2"	5.625	5.625	5.625	5.625	0.109
B7RWWW-R600300P	6" x 3"	5.625	5.625	5.625	5.625	0.109
B7RWWW-R600400P	6" x 4"	5.625	5.625	5.625	5.625	0.109

Polished 316L Stainless Steel.

POLISHED REDUCERS – BUTT WELD CONCENTRIC REDUCER – B31W

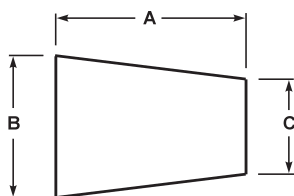
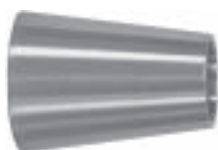

PART NO.	TUBE O.D.	DIMENSION			NOMINAL WALL
		A	B	C	
B31W-R7550P	¾" x ½"	1.000	0.750	0.500	0.065
B31W-R10050P	1" x ½"	2.000	1.000	0.500	0.065
B31W-R10075P	1" x ¾"	1.000	1.000	0.750	0.065
B31W-R15050P	1½" x ½"	4.000	1.500	0.500	0.065
B31W-R15075P	1½" x ¾"	3.000	1.500	0.750	0.065
B31W-R150100P	1½" x 1"	2.000	1.500	1.000	0.065
B31W-R20050P	2" x ½"	6.000	2.000	0.500	0.065
B31W-R20075P	2" x ¾"	5.000	2.000	0.750	0.065
B31W-R200100P	2" x 1"	4.000	2.000	1.000	0.065
B31W-R200150P	2" x 1½"	2.000	2.000	1.500	0.065
B31W-R250150P	2½" x 1½"	4.000	2.500	1.500	0.065
B31W-R250200P	2½" x 2"	2.000	2.500	2.000	0.065
B31W-R300100P	3" x 1"	8.000	3.000	1.000	0.065
B31W-R300150P	3" x 1½"	6.000	3.000	1.500	0.065
B31W-R300200P	3" x 2"	4.000	3.000	2.000	0.065
B31W-R300250P	3" x 2½"	2.000	3.000	2.500	0.065
B31W-R400150P	4" x 1½"	10.000	4.000	1.500	0.083
B31W-R400200P	4" x 2"	8.000	4.000	2.000	0.083
B31W-R400250P	4" x 2½"	6.000	4.000	2.500	0.083
B31W-R400300P	4" x 3"	4.000	4.000	3.000	0.083
B31W-R600200P	6" x 2"	5.500	6.000	2.000	0.109
B31W-R800400P	8" x 4"	6.000	8.000	4.000	0.120
B31W-R800600P	8" x 6"	6.000	8.000	6.000	0.120

Polished 316L Stainless Steel.

POLISHED REDUCERS – BUTT WELD ECCENTRIC REDUCER – B32W

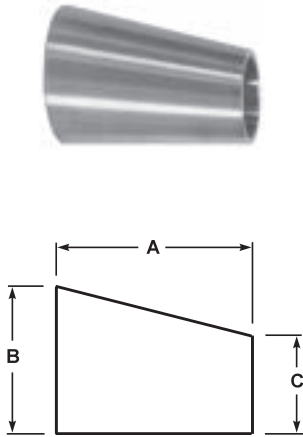

PART NO.	TUBE O.D.	DIMENSION			NOMINAL WALL
		A	B	C	
B32W-R7550P	¾" x ½"	1.000	0.750	0.500	0.065
B32W-R10050P	1" x ½"	2.000	1.000	0.500	0.065
B32W-R10075P	1" x ¾"	1.000	1.000	0.750	0.065
B32W-R15050P	1½" x ½"	4.000	1.500	0.500	0.065
B32W-R15075P	1½" x ¾"	3.000	1.500	0.750	0.065
B32W-R150100P	1½" x 1"	2.000	1.500	1.000	0.065
B32W-R20050P	2" x ½"	6.000	2.000	0.500	0.065
B32W-R20075P	2" x ¾"	5.000	2.000	0.750	0.065
B32W-R200100P	2" x 1"	4.000	2.000	1.000	0.065
B32W-R200150P	2" x 1½"	2.000	2.000	1.500	0.065
B32W-R250150P	2½" x 1½"	4.000	2.500	1.500	0.065
B32W-R250200P	2½" x 2"	2.000	2.500	2.000	0.065
B32W-R300150P	3" x 1½"	6.000	3.000	1.500	0.065
B32W-R300200P	3" x 2"	4.000	3.000	2.000	0.065
B32W-R300250P	3" x 2½"	2.000	3.000	2.500	0.065
B32W-R400150P	4" x 1½"	10.000	4.000	1.500	0.083
B32W-R400200P	4" x 2"	8.000	4.000	2.000	0.083
B32W-R400250P	4" x 2½"	6.000	4.000	2.500	0.083
B32W-R400300P	4" x 3"	4.000	4.000	3.000	0.083

Polished 316L Stainless Steel.

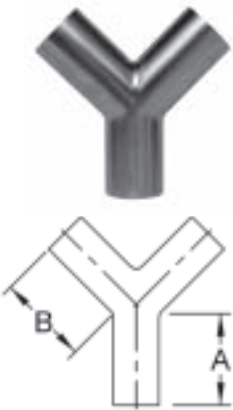

POLISHED TRUE (EQUAL) BUTT WELD "Y"

PART NO.	TUBE O.D.	DIMENSION		NOMINAL WALL
		A	B	
B28W-R100P	1"	2.000	2.438	0.065
B28W-R150P	1½"	2.000	2.438	0.065
B28W-R200P	2"	2.625	3.250	0.065
B28W-R250P	2½"	3.370	4.125	0.065
B28W-R300P	3"	4.000	4.875	0.065
B28W-R400P	4"	5.375	5.375	0.083

Polished 316L Stainless Steel.

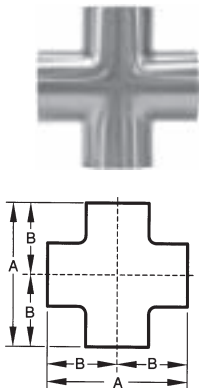

POLISHED TRUE (EQUAL) BUTT WELD "Y"

PART NO.	TUBE O.D.	DIMENSION		NOMINAL WALL
		A	B	
B9WWWW-R100P	1"	2.250	1.125	0.065
B9WWWW-R150P	1½"	3.312	1.656	0.065
B9WWWW-R200P	2"	4.125	2.062	0.065
B9WWWW-R250P	2½"	4.687	2.343	0.065
B9WWWW-R300P	3"	5.187	2.593	0.065
B9WWWW-R400P	4"	6.875	3.437	0.083

Polished 316L Stainless Steel.

Unpolished Bends, Tee's & Reducers

All Dixon unpolished fittings are either bright annealed or tumbled.

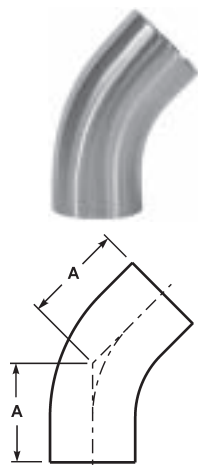

45° UNPOLISHED ELBOWS - BUTT WELD B2KS

PART NO.	TUBE O.D.	DIMENSION A	NOMINAL WALL
B2KS-R50U	1/2"	2.250	0.065
B2KS-R75U	3/4"	2.250	0.065
B2KS-R100U	1"	1.188	0.065
B2KS-R150U	1 1/2"	1.625	0.065
B2KS-R200U	2"	2.312	0.065
B2KS-R250U	2 1/2"	3.000	0.065
B2KS-R300U	3"	3.688	0.065
B2KS-R400U	4"	4.812	0.083

Unpolished 316L Stainless Steel.

G

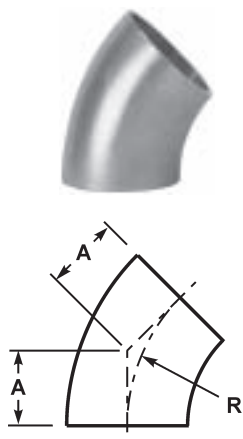

UNPOLISHED ELBOWS LESS TANGENT - B2WK

PART NO.	TUBE O.D.	DIMENSION		NOMINAL WALL
		A	R	
B2WK-R50U	1/2"	.466	1.125	0.065
B2WK-R75U	3/4"	.466	1.125	0.065
B2WK-R100U	1"	.625	1.500	0.065
B2WK-R150U	1 1/2"	.937	2.250	0.065
B2WK-R200U	2"	1.250	3.000	0.065
B2WK-R250U	2 1/2"	1.562	3.750	0.065
B2WK-R300U	3"	1.875	4.500	0.065
B2WK-R400U	4"	2.500	6.000	0.083
B2WK-R600U	6"	3.750	9.000	0.109
B2WK-R800U	8"	5.000	12.000	0.120
B2WK-R1000U	10"	6.250	15.000	0.109
B2WK-R1200U	12"	7.500	18.000	0.120

Unpolished 316L Stainless Steel.

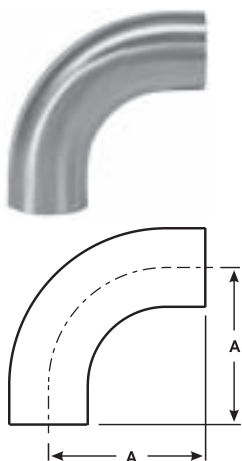

90° UNPOLISHED ELBOWS - BUTT WELD ELBOWS WITH TANGENT - B2S

PART NO.	TUBE O.D.	Dimension A	Nominal Wall
B2S-R50U	1/2"	3.000	0.065
B2S-R75U	3/4"	3.000	0.065
B2S-R100U	1"	2.062	0.065
B2S-R150U	1 1/2"	2.937	0.065
B2S-R200U	2"	4.062	0.065
B2S-R250U	2 1/2"	5.187	0.065
B2S-R300U	3"	6.312	0.065
B2S-R400U	4"	8.312	0.083

Unpolished 316L Stainless Steel.

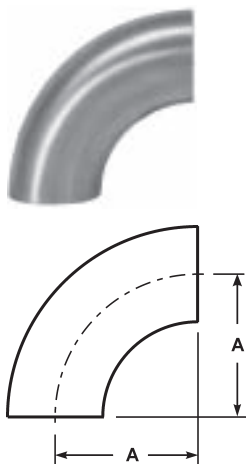

90° UNPOLISHED ELBOWS – BUTT WELD ELBOWS LESS TANGENT – B2WCL

PART NO.	TUBE O.D.	DIMENSION A	NOMINAL WALL
B2WCL-R50U	½"	1.125	0.065
B2WCL-R75U	¾"	1.125	0.065
B2WCL-R100U	1"	1.500	0.065
B2WCL-R150U	1½"	2.250	0.065
B2WCL-R200U	2"	3.000	0.065
B2WCL-R250U	2½"	3.750	0.065
B2WCL-R300U	3"	4.500	0.065
B2WCL-R400U	4"	6.000	0.083
B2WCL-R600U	6"	9.000	0.109
B2WCL-R800U	8"	12.000	0.120
B2WCL-R1000U	10"	15.000	0.109

Unpolished 316L Stainless Steel.

G

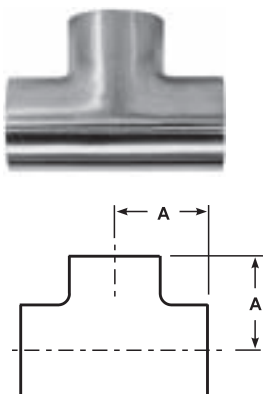

UNPOLISHED TEES – BUTT WELD / SHORT TEE-B7WWW

PART NO.	TUBE O.D.	DIMENSION A	NOMINAL WALL
B7WWW-R100U	1"	1.125	0.065
B7WWW-R150U	1½"	1.656	0.065
B7WWW-R200U	2"	2.062	0.065
B7WWW-R250U	2½"	2.344	0.065
B7WWW-R300U	3"	2.594	0.065
B7WWW-R400U	4"	3.438	0.083

Unpolished 316L Stainless Steel.

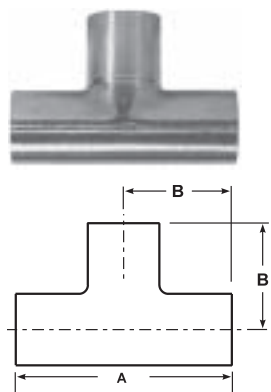

UNPOLISHED TEES – BUTT WELD / LONG TEE – B7W

PART NO.	TUBE O.D.	DIMENSION		NOMINAL WALL
		A	B	
B7W-R50U	½"	3.750	1.875	0.065
B7W-R75U	¾"	4.000	2.000	0.065
B7W-R100U	1"	3.750	1.875	0.065
B7W-R150U	1½"	4.500	2.250	0.065
B7W-R200U	2"	6.000	3.000	0.065
B7W-R250U	2½"	6.000	3.000	0.065
B7W-R300U	3"	6.500	3.250	0.065
B7W-R400U	4"	7.750	3.875	0.083
B7W-R800U	8"	14.000	7.000	0.120

Unpolished 316L Stainless Steel.

Unpolished Bends, Tee's & Reducers

UNPOLISHED TEES – BUTT WELD / REDUCING TEE – B7RWWW

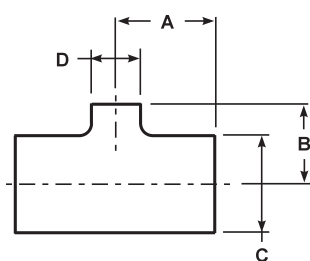

PART NO.	TUBE O.D.	DIMENSION				NOMINAL WALL
		A	B	C	D	
B7RWWW-R7550U	¾" x ½"	2.000	2.000	2.000	2.000	0.065
B7RWWW-R10050U	1" x ½"	2.125	2.125	2.125	2.125	0.065
B7RWWW-R10075U	1" x ¾"	2.125	2.125	2.125	2.125	0.065
B7RWWW-R15050U	1½" x ½"	2.375	2.375	2.375	2.375	0.065
B7RWWW-R15075U	1½" x ¾"	2.375	2.375	2.375	2.375	0.065
B7RWWW-R150100U	1½" x 1"	1.656	1.656	1.656	1.656	0.065
B7RWWW-R20050U	2" x ½"	2.875	2.875	2.875	2.875	0.065
B7RWWW-R20075U	2" x ¾"	2.875	2.875	2.875	2.875	0.065
B7RWWW-R200100U	2" x 1"	2.062	2.062	2.062	2.062	0.065
B7RWWW-R200150U	2" x 1½"	2.062	2.062	2.062	2.062	0.065
B7RWWW-R250150U	2½" x 1½"	2.344	2.344	2.344	2.344	0.065
B7RWWW-R250200U	2½" x 2"	2.344	2.344	2.344	2.344	0.065
B7RWWW-R300150U	3" x 1½"	2.594	2.594	2.594	2.594	0.065
B7RWWW-R300200U	3" x 2"	2.594	2.594	2.594	2.594	0.065
B7RWWW-R300250U	3" x 2½"	2.594	2.594	2.594	2.594	0.083
B7RWWW-R400150U	4" x 1½"	3.438	3.438	3.438	3.438	0.083
B7RWWW-R400200U	4" x 2"	3.438	3.438	3.438	3.438	0.083
B7RWWW-R400250U	4" x 2½"	3.438	3.438	3.438	3.438	0.083
B7RWWW-R400300U	4" x 3"	3.438	3.438	3.438	3.438	0.083
B7RWWW-R600200U	6" x 2"	5.625	5.625	5.625	5.625	0.109
B7RWWW-R600300U	6" x 3"	5.625	5.625	5.625	5.625	0.109
B7RWWW-R600400U	6" x 4"	5.625	5.625	5.625	5.625	0.109

Unpolished 316L Stainless Steel.

UNPOLISHED REDUCERS – BUTT WELD CONCENTRIC REDUCER – B31W

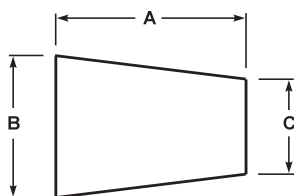
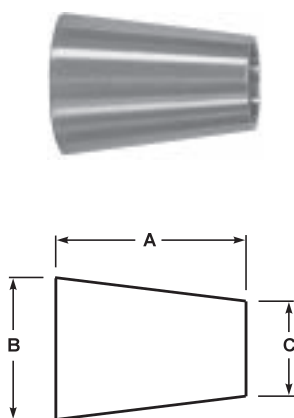

PART NO.	TUBE O.D.	DIMENSION			NOMINAL WALL
		A	B	C	
B31W-R7550U	¾" x ½"	1.000	0.750	0.500	0.065
B31W-R10050U	1" x ½"	2.000	1.000	0.500	0.065
B31W-R10075U	1" x ¾"	1.000	1.000	0.750	0.065
B31W-R15050U	1½" x ½"	4.000	1.500	0.500	0.065
B31W-R15075U	1½" x ¾"	3.000	1.500	0.750	0.065
B31W-R150100U	1½" x 1"	2.000	1.500	1.000	0.065
B31W-R20050U	2" x ½"	6.000	2.000	0.500	0.065
B31W-R20075U	2" x ¾"	5.000	2.000	0.750	0.065
B31W-R200100U	2" x 1"	4.000	2.000	1.000	0.065
B31W-R200150U	2" x 1½"	2.000	2.000	1.500	0.065
B31W-R250150U	2½" x 1½"	4.000	2.500	1.500	0.065
B31W-R250200U	2½" x 2"	2.000	2.500	2.000	0.065
B31W-R300100U	3" x 1"	8.000	3.000	1.000	0.065
B31W-R300150U	3" x 1½"	6.000	3.000	1.500	0.065
B31W-R300200U	3" x 2"	4.000	3.000	2.000	0.065
B31W-R300250U	3" x 2½"	2.000	3.000	2.500	0.065
B31W-R400150U	4" x 1½"	10.000	4.000	1.500	0.083
B31W-R400200U	4" x 2"	8.000	4.000	2.000	0.083
B31W-R400250U	4" x 2½"	6.000	4.000	2.500	0.083
B31W-R400300U	4" x 3"	4.000	4.000	3.000	0.083
B31W-R600200U	6" x 2"	5.500	6.000	2.000	0.109
B31W-R800400U	8" x 4"	6.000	8.000	4.000	0.120
B31W-R800600U	8" x 6"	6.000	8.000	6.000	0.120

Unpolished 316L Stainless Steel.

UNPOLISHED REDUCERS – BUTT WELD ECCENTRIC REDUCER – B32W

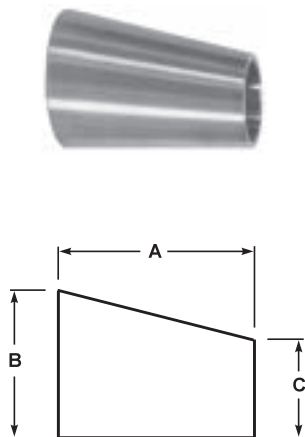

PART NO.	TUBE O.D.	DIMENSION			NOMINAL WALL
		A	B	C	
B32W-R7550U	¾" x ½"	1.000	0.750	0.500	0.065
B32W-R10050U	1" x ½"	2.000	1.000	0.500	0.065
B32W-R10075U	1" x ¾"	1.000	1.000	0.750	0.065
B32W-R15050U	1½" x ½"	4.000	1.500	0.500	0.065
B32W-R15075U	1½" x ¾"	3.000	1.500	0.750	0.065
B32W-R150100U	1½" x 1"	2.000	1.500	1.000	0.065
B32W-R20050U	2" x ½"	6.000	2.000	0.500	0.065
B32W-R20075U	2" x ¾"	5.000	2.000	0.750	0.065
B32W-R200100U	2" x 1"	4.000	2.000	1.000	0.065
B32W-R200150U	2" x 1½"	2.000	2.000	1.500	0.065
B32W-R250150U	2½" x 1½"	4.000	2.500	1.500	0.065
B32W-R250200U	2½" x 2"	2.000	2.500	2.000	0.065
B32W-R300150U	3" x 1½"	6.000	3.000	1.500	0.065
B32W-R300200U	3" x 2"	4.000	3.000	2.000	0.065
B32W-R300250U	3" x 2½"	2.000	3.000	2.500	0.065
B32W-R400150U	4" x 1½"	10.000	4.000	1.500	0.083
B32W-R400200U	4" x 2"	8.000	4.000	2.000	0.083
B32W-R400250U	4" x 2½"	6.000	4.000	2.500	0.083
B32W-R400300U	4" x 3"	4.000	4.000	3.000	0.083

Unpolished 316L Stainless Steel.

G

UNPOLISHED TRUE (EQUAL) BUTT WELD "Y"

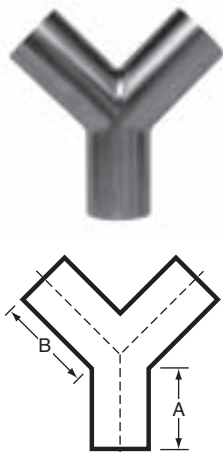

PART NO.	TUBE O.D.	DIMENSION		NOMINAL WALL
		A	B	
B28W-R100U	1"	2.000	2.438	0.065
B28W-R150U	1½"	2.000	2.438	0.065
B28W-R200U	2"	2.625	3.250	0.065
B28W-R250U	2½"	3.370	4.125	0.065
B28W-R300U	3"	4.000	4.875	0.065
B28W-R400U	4"	5.375	5.375	0.083

Unpolished 316L Stainless Steel.